



ACION 8000 Series

A8KQDR - Quad Digital Return Receiver

The A8KQDR Quad Digital Return Receiver is an integral part of the HFC system. It utilizes state-of-the-art digital return technology that allows deployment of compact and highly robust high-speed digital data for the broadband systems. The A8KQDR is a 3RU module and up to 12 modules can reside in the 19-in high density chassis (A8KMF3).

ACI's A8KQDR employs two hot pluggable Rx-SFPs at the receiver in the front and four RF outputs at the back that allows the bandwidth to be changed in the field from 5-45 MHz to 5-85 MHz operation. Furthermore, the A8KQDR, with advanced design and path segmentation can work with mixed bandwidths by accepting one 45 MHz Rx-SFP and one 85 MHz Rx-SFP. With the mixed BW Rx-SFPs, the A8KQDR can provide two 45 MHz outputs and two 85 MHz outputs.

Features

- 3RU module for 19" rack housing
- 45 MHz / 85 MHz bandwidth selectable with field exchangeable SFP sub module
- Dual hot-swap field upgradable SFP return receiver sub module
- 4 Return RF outputs
- Maximum of 48 returns for Quad receiver modules per chassis
- High RF output @ 36 dBmV / 6.4 MHz channel for 45 MHz or 85 MHz operation
- Optical wavelength: 1260 to 1620 nm
- Hot-swappable
- -20dB RF test point on front panel, selectable for each input
- Remote monitor and control function by HMS or SNMP

Block Diagram

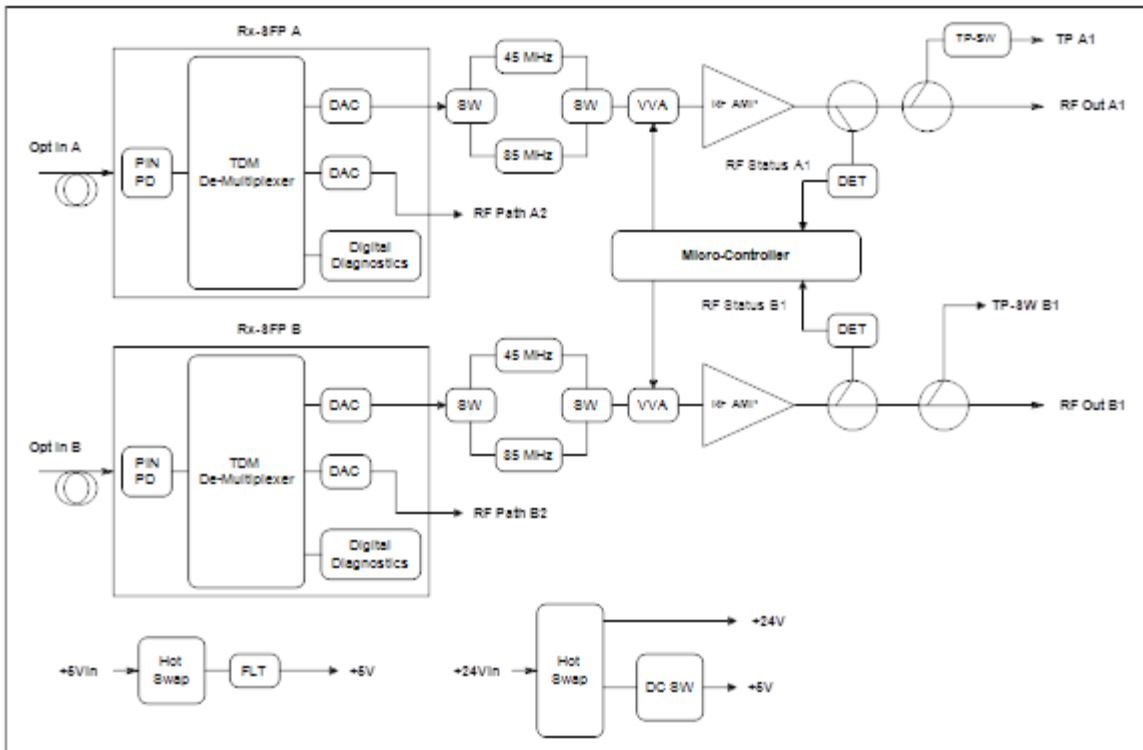

Digital Return 2-fer Path (single fiber per SFP)

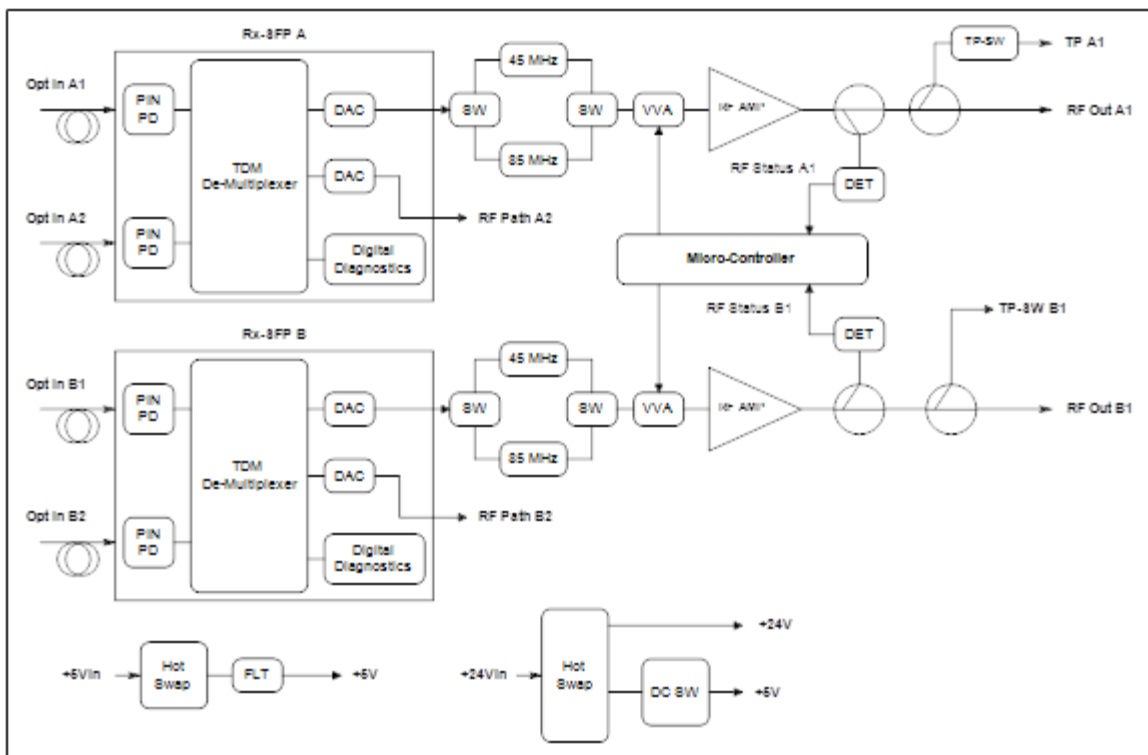

Digital Return Dual Path (two fibers per SFP)

Specifications

ACI		ACION 8000 Series A8KQDR Quad Digital Return Receiver		
PARAMETERS	CONDITIONS	UNITS	SPECIFICATION	NOTES
Optical Specification				
Input Optical Power		dBm	-18 to -5	
Optical Return Loss		dB	45	
Receive Optical Power		dBm	-18 to -5	
Optical Wavelength		nm	1260 to 1620	
RF Specifications				
Operating Bandwidth	45 MHz 85 MHz	MHz	5 to 45 5 to 85	
A1, A2, B1, B2 Output Return Loss	Max.	dB	-16	
A1, A2, B1, B2 RF Output Level	Typical	dBmV/ch	36	
RF Path Gain Adjustment Range	0.1 dB steps	dB	0 to 20	
A1, A2, B1, B2 Flatness	Link	dBpk-pk	±1	
RF Output Test Point Level		dB	-20 ± 0.5	
RF Output Test Point Return Loss	Max.	-dB	16	
Receiver to Receiver Isolation		dB	<-50	
Receiver EIN	Max.	pA/√Hz	7	
Link Performance (10 km) with A34XMTDR				
Link Gain		dB	20	
Peak NPR	45 MHz 85 MHz	dB	53 52	
Dynamic Range	@40dB NPR	dB	18	
MER		dB	38	
BER			<1x10 ⁻⁹	
Environment				
Module width		slot	1	
Power consumption	Max.	W	17.5	
Operating temperature		°F(°C)	32 to 122 (0 to 50)	
Relative humidity	Non-condensing	%	0 to 95	
Optical connector			LC/UPC	
Dimensions	D × H × W	Inch. (mm)	16.1 × 5.0 × 1.0 (410 × 127 × 26)	

Ordering Matrix

A8KQDR Configuration Sheet

Customer: _____
 Created By: _____ Order Date: _____

ORDERING MATRIX

July 6, 2020

	1			2	3		4	5	6	7	8	9	10
A 8 K		D R	—			—							

1 **Number of Receiver ports in module**
 D = 2 ports
 Q = 4 ports (standard)

2~3 **Number of Input Fiber & WDM**
 00 = Without SFP
 02 = 1 Fiber
 04 = 2 Fiber
 08 = 4 Fiber

4~5 **A/B Switch for redundant or not redundant receivers**
 00 = Without A/B Switch for Non-redundant receivers

6~7 **Connector**
 00 = Without SFP
 LC = LC/APC

8~10 **Digital Return Receiver Module & RF output**
 000 = Without SFP
 412 = 45MHz, Single PIN Receiver, Dual RF Output (2-fer)
 422 = 45MHz, Dual PIN Receiver, Dual RF Output
 812 = 85MHz, Single PIN Receiver, Dual RF Output (2-fer)
 822 = 85MHz, Dual PIN Receiver, Dual RF Output

SFP Module Part Numbers:

Part Number	Description
SUMA-RX-21X-00	45 MHz, Single PIN receiver, Dual RF output (2-fer)
SUMA-RX-31X-00	45 MHz, Dual PIN receiver, Dual RF output
SUMA-RX-81X-00	85 MHz, Single PIN receiver, Dual RF output (2-fer)
SUMA-RX-91X-00	85 MHz, Dual PIN receiver, Dual RF output



ACI Communications, Inc.
 23307 66th Avenue South
 Kent, WA 98032

Rev G 07-06-2020 Printed in U.S.A.
 ACI Communications, Inc. reserves the right to discontinue the manufacture or change specifications without prior notice on any parts illustrated in this data sheet. Registered trademarks are the property of their respective owner