



ACION 8000 Series

A8KEAM 1550nm (C-Band) EDFA Module

A8KEAM (C-Band) EDFA(Erbium-Doped Fiber Amplifier) module is designed to for long-haul or wide broadcast optical fiber systems. It is a compact, highly reliable, scalable and cost-effective unit. The module is hot-swappable with integrated management through A8KPCM and remote management by HMS or SNMP. A maximum of 16 application modules can reside in the 19-inch, high-density chassis (A8KMF3). An output monitoring port is available for real-time monitoring without service interruption.

Features

- ◆ High output power
- ◆ Low noise figure
- ◆ Operating windows: 1540~1560 nm
- ◆ Optical input power from -5 ~ 8 dBm
- ◆ Optical output power from 17 ~ 23 dBm
- ◆ Low power consumption
- ◆ Remote control and status monitor
- ◆ Hot-swappable
- ◆ SMF-28 Type Input/Output Optical Fiber
- ◆ Booster amplifier for long haul broadcast
- ◆ Single channel application
- ◆ Advanced alarm functions
- ◆ SC/APC with shutter(standard), FC/APC, or E2000/APC (optional) connector types.

Block Diagrams

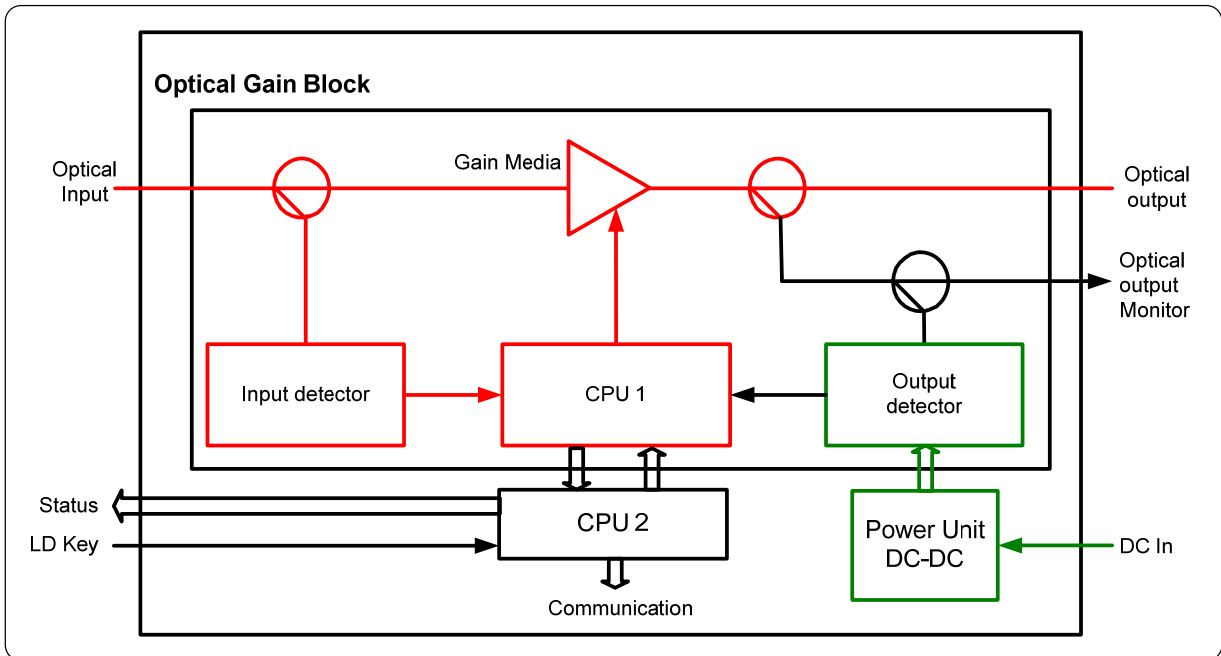

Application

In an FTTx Network, 1550 nm wavelength is usually used for the RF signal transport. The RF signal is launched from an optical transmitter, through an optical amplifier, and then linked to a V-ONU at the subscriber's house.

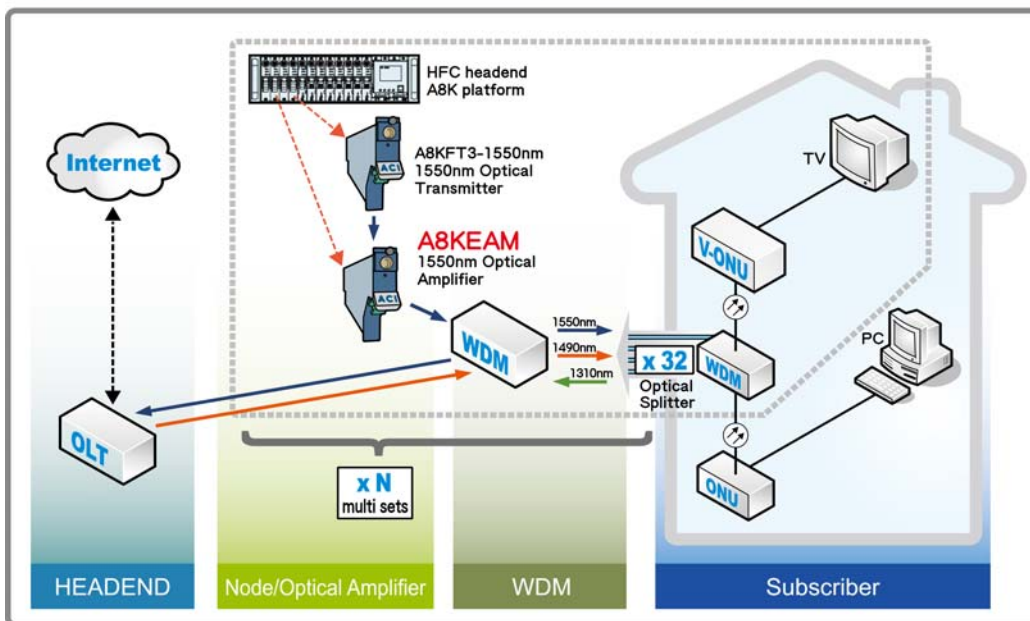

Specifications

ACI		ACION8000 Series A8KEAM 1550 nm (C-Band) EDFA Module		
PARAMETERS	CONDITIONS	UNITS	SPECIFICATION	NOTES
Optical Specifications				
Optical Wavelength		nm	1540 ~ 1560	
Connector Type			SC/APC (standard) FC/APC, E2000/APC (optional)	
Optical Input Power		dBm	-5 ~ +8	
Optical Saturation Output Power		dBm	17 ~ 23	
Noise Figure	Pin = 0 dBm λ = 1550 nm	dB	5	
Optical Return Loss	Min.	dB	45	
Polarization Dependent Gain	Max.	dB	0.5	
Polarization Mode Dispersion	Max.	ps	1	
Input/Output Optical Fiber			SMF-28	
Electrical/Environmental/Mechanical				
Module Width		slot	1	
Operating Temperature		°F (°C)	32 to 122 (0 to 50)	
Storage Temperature		°F (°C)	-40 to 149 (-40 to 65)	
Power Supply Voltage		V	24 ± 0.5	
Power Supply Current		A	1.2 @ 24 VDC	
Power Consumption	Max.	W	30	
Relative Humidity	Non-condensing	%	0 ~ 95	
Dimensions	W x D x H	Inch (mm)	16.1 x 5 x 1 (410 x 127 x 25.9)	
Alarm Functions				
Case Temperature High Alarm		°F (°C)	158 (70)	
Output high/low Alarm		dB	< -2 or > +2	
Input high/low Alarm		dBm	< -5 or > +8	
Pump LD Bias High Alarm		mA	> LD Link Current	LD Shut Down ★1
Pump LD Temp. High Alarm		°F (°C)	> 80.5 (27)	
Pump LD Shutdown by Input Power		dBm	< -12	

★1: LD Output Shut Down Function by LD Bias high, LD Temperature high, or low Input Power.

Ordering Matrix

A8KEAM 1550nm (C-Band) EDFA Configuration Sheet

Customer: _____

Created By: _____

ORDERING MATRIX

2010/5/13

Position		1	2	3	4
PART NUMBER	A8KEAM-1550nm	—		—	

1-2 Output Power

1	7	= 17 dBm
1	8	= 18 dBm
1	9	= 19 dBm
2	0	= 20 dBm
2	1	= 21 dBm
2	2	= 22 dBm
2	3	= 23 dBm

3.4 Connector

S	C	= SC/APC with shutter (standard)
F	C	= FC/APC (option)
E	C	= E2000/APC (option)

NOTES:



ACI Communications, Inc.
23307 66th Avenue South
Kent, WA 98032

Rev F 10-28-2015 Printed in U.S.A.
ACI Communications, Inc. reserves the right to discontinue the manufacture or change specifications without prior notice on any parts illustrated in this data sheet. Registered trademarks are the property of their respective owner